



# W8 - W8 EASY

## sottovuoto packaging machines

- Straordinario design riduce l'ingombro della macchina e migliora la praticità
- Campana a grande sviluppo di volume in plexiglass termoformato di grosso spessore sui mod. 50 e 70, ad iniezione sui mod. 30 e 40
- Barra saldante facilmente rimovibile
- Estrema facilità di pulizia grazie alla perfetta planarità del piano di appoggio prodotto.
- Sollevamento coperchio automatico a mezzo di pistoncini pneumatici.

### Sistema di controllo elettronico con:

- selezione 6 lingue
- impostazione tempo saldatura, vuoto e gas con scala 1/10 sec.
- visualizzazione percentuale vuoto e tempo residuo
- 8 programmi memorizzabili a piacere
- programma A = vuoto automatico
- programma X = aspirazione esterna a tempo
- programma XA = aspirazione esterna automatica
- Percentuale vuoto automatico regolabile 50-100%
- segnale di avviso sostituzione olio.
- Protezione termica pompa
- Ciclo di preriscaldamento e pulizia olio
- Contacigli totali
- Contatore utilizzo pompa

### Opzionali:

- Impianto per gas inerte (MAP) e soft air
- Stampante termica automatica per data, ora e dati confezionamento
- Piano regolabile per buste con liquidi
- Piano in polietilene per rialzo e contenimento.
- Tubo per aspirazione esterna
- Vasche GN per aspirazione esterna.

### W8 30-40-50-70

- Pompa aspirazione Bush.
- Piano posizionamento prodotto in acciaio inox AISI 304 spessore 5 mm.

### W8 30-40-50 S

- Piano posizionamento prodotto smaltato per una facile igiene



W8 70 BX TB

### W8 30-40 Easy

- "Easy" identifica una scheda comando semplificata, che garantisce comunque tutte le principali funzioni necessarie per un uso professionale e completo.
- Tutte le altre caratteristiche tecniche e funzionali della macchina rimangono le stesse della versione più completa.
- Facile settaggio del tempo di vuoto e di saldatura
- Visualizzazione percentuale vuoto e tempo residuo
- Memorizzazione ultima impostazione
- Contacigli e contatore utilizzo pompa
- Preriscaldamento pompa e ciclo pulizia olio
- Messaggio cambio olio
- Vuoto esterno a tempo
- Non disponibile con stampante o Gas
- Campana ad iniezione con grande sviluppo di volume
- Sollevamento coperchio automatico a mezzo di pistoncini pneumatici
- Barra saldante facilmente rimovibile.

- Exceptional design to reduce machine size and improve its practicality
- Large and wide bell in thermoformed plexiglass on mod. 50 and 70, injection on mod. 30 and 40
- Easily removable sealing bar
- Extremely easy to clean thanks to a perfectly level product counter.
- Automatic cover lift operated by pneumatic pistons.

### Electronic control system featuring:

- 6 selectable languages
- Settable sealing, vacuum and gas time on a scale 1-10 sec.
- Display of vacuum percentage and time to countdown
- 8 different settings savable to preference
- Setting A = automatic vacuum
- Setting A = timed external suction
- Setting XA = automatic external suction
- Adjustable automatic vacuum percentage: 50-100%
- oil change warning light.
- Thermal pump guard



W8 30 EASY DS



W8 30 BX



W8 40 DX + GAS + SOFT AIR



1. Controllo elettronico semplice ed intuitivo  
*User-friendly, intuitive operation*



2. Sistema sospensione coperchio ammortizzato  
*Cushion-hinged lid*



3. Stampante integrata opzionale  
*Optional integrated printer*



4. Opzione gas inerte e soft air (escluse le EASY)  
*Inert gas system and soft air option (not available on EASY)*



5. Barra saldante standard  
*Standard sealing bar*



6. Doppia barra saldante W8 50 DB  
*Double sealing bar W8 50 DB*



7. Tripla barra saldante W8 70 TB  
*Triple sealing bar W8 70 TB*



8. Estrema facilità di pulizia  
*Easy cleaning*

- Oil preheat and cleaning cycle
- Total rev counter
- Pump meter

*Optional accessories:*

- Inert gas system (MAP) and soft air
- Automatic thermal printer by date, time and packing specifications
- Adjustable surface for liquid bags
- Counter in polyethylene for lifting and containment.
- Hose for external suction
- GN tanks for external suction.

**W8 30-40-50-70**

- Bush suction pump.
- 5 mm thick, AISI 304 stainless steel, easy to clean plain vacuum chamber.

**W8 30-40-50 S**

- Glazed product holding surface for an easy hygiene

**W8 30-40 Easy**

- "Easy" identifies a simplified control board that provides all the main functions necessary for a complete professional use.
- All the other technical and functional specifications of the machine are the same as in the amplified version.
- Easy vacuum and sealing time setting.
- Display of vacuum percentage and time to countdown.
- Last setting saved in memory.
- Rev counter and pump meter.
- Pump preheating and oil cleaning cycle.
- Oil change message.
- Timed external vacuum.
- Not available with printer or Gas.
- Large injection bells.
- Automatic cover lift operated by pneumatic pistons.
- Easily removable sealing bar.



9. Cavalletto alluminio per W8 50 - opzionale con e senza ruote - mm 586x564 h.757  
*Aluminium table base for W8 50 - optional with and without wheels - mm 586x564 h.757*



10. Piano regolabile per liquidi opzionale  
Optional adjustable insert plate for liquids

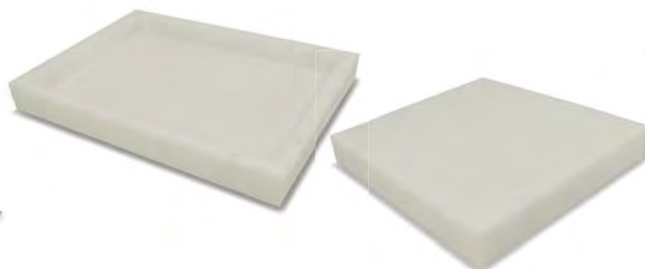

11. Piano in polietilene per rialzo e contenimento opzionale  
Optional polyethylene plate for containment and upward



12. Tubo per aspirazione esterna opzionale  
Optional tube for external air extraction



13. Contenitori Gastro 1/1 - 1/2 - 1/3 (h.100/150)  
Gastro trays 1/1 - 1/2 - 1/3 (h.100/150)



14. Facile manutenibilità  
Easy access for service



Buste per sottovuoto lisce  $\mu$ m 95  
Vacuum bags smooth  $\mu$ m 95

- cm 17x25
- cm 20x30
- cm 25x35
- cm 30x40
- cm 35x45
- cm 40x50



Buste per sottovuoto goffrate  $\mu$ m 90  
Vacuum bags embossed  $\mu$ m 90

- cm 20x30
- cm 25x35
- cm 30x40
- cm 35x45
- cm 40x50



Buste per cottura sottovuoto  $\mu$ m 80  
Cooking vacuum bags  $\mu$ m 80

- cm 15x20
- cm 20x30
- cm 25x35
- cm 30x40

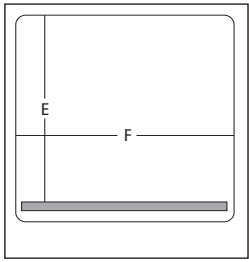

W8 30-40-50

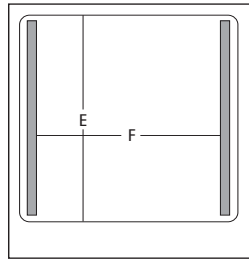

W8 50DB

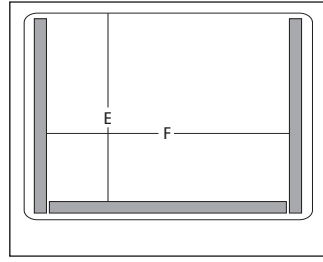

W8 70TB

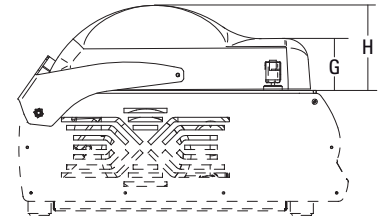

**IDENTIFICAZIONE MODELLI**

- D = Pompa DVP
- B = Pompa Busch
- X = piano appoggio inox 5 mm
- S = piano appoggio smaltato 5 mm
- 12 = pompa aspirazione 12 mc
- DB = doppia barra saldante
- TB = tripla barra saldante

**MODELS IDENTIFICATION**

- D = DVP suction pump
- B = Bush suction pump
- X = s/steel surface
- S = glazed surface
- 12 = Pump out standart 12 mc
- DB = Double sealing bar
- TB = Triple sealing bar

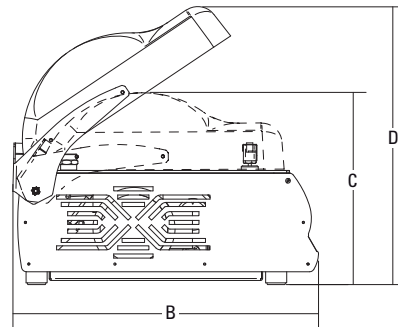
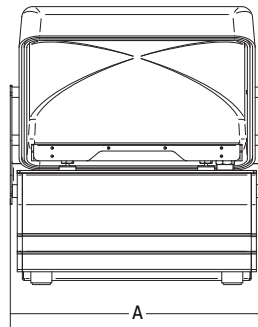

	Potenza Power Spannung Puissance	Alimentazione Power source Betriebsspannung Alimentation	Pompa del vuoto Vacuum pump Vacuum pumpe Pompe de vide	Barra saldante Sealing bar Schweißstee Barre de souder	Dimensioni camera Cavity dimensions Kammergrösse Dimensiones de la chambre	A	B	C	D	E	F	G	H	Peso netto Net weight Nettogewicht Poids net	Dimensioni imballo Shipping Verpack. abmessungen Dim. emballage	Peso lordo Gross weight Bruttogewicht Poids brut
	Kw	mc/h	mm	mm	mm	mm	mm	mm	mm	mm	mm	mm	mm	Kg	mm	kg
W8 30 Easy DS	0,35	230V/50Hz	8	310	340x360 h.150	402	525	370	480	334	340	85	160	38	720x570x770	48
W8 30 Easy DX	0,35	230V/50Hz	8	310	340x360 h.150	402	525	370	480	334	340	85	160	38	720x570x770	48
W8 30 Easy BX	0,35	230V/50Hz	8	310	340x360 h.150	402	525	370	480	334	340	85	160	38	720x570x770	48
W8 30 Easy DX 12	0,35	230V/50Hz	12	310	340x360 h.150	402	525	370	480	334	340	85	160	38	720x570x770	48
W8 30 DS	0,35	230V/50Hz	8	310	340x360 h.150	402	525	370	480	334	340	85	160	38	720x570x770	48
W8 30 DX	0,35	230V/50Hz	8	310	340x360 h.150	402	525	370	480	334	340	85	160	38	720x570x770	48
W8 30 BX	0,35	230V/50Hz	8	310	340x360 h.150	402	525	370	480	334	340	85	160	38	720x570x770	48
W8 30 DX 12	0,45	230V/50Hz	12	310	340x360 h.150	402	525	370	480	334	340	85	160	38	720x570x770	48
W8 40 Easy DS 12	0,45	230V/50Hz	12	410	430x410 h.160	493	585	370	480	334	430	85	170	54	760x640x770	66
W8 40 Easy DX 12	0,45	230V/50Hz	12	410	430x410 h.160	493	585	370	480	334	430	85	170	54	760x640x770	66
W8 40 Easy DS	0,75	230V/50Hz	21	410	430x410 h.160	493	585	370	480	334	430	85	170	56	760x640x770	66
W8 40 Easy DX	0,75	230V/50Hz	21	410	430x410 h.160	493	585	370	480	334	430	85	170	56	760x640x770	66
W8 40 Easy BX	0,75	230V/50Hz	21	410	430x410 h.160	493	585	370	480	334	430	85	170	56	760x640x770	66
W8 40 DS	0,75	230V/50Hz	21	410	430x410 h.160	493	585	370	542	390	430	85	170	56	760x640x770	66
W8 40 DX	0,75	230V/50Hz	21	410	430x410 h.160	493	585	370	542	390	430	85	170	56	760x640x770	66
W8 40 BX	0,75	230V/50Hz	21	410	430x410 h.160	493	585	370	542	390	430	85	170	56	760x640x770	66
W8 50 DS	0,75	230V/50Hz	21	510	545x460 h.190	609	640	420	605	430	540	90	210	70	840x870x750	86
W8 50 DX	0,75	230V/50Hz	21	510	545x460 h.190	609	640	420	605	430	540	90	210	70	840x870x750	86
W8 50 BX	0,75	230V/50Hz	21	510	545x460 h.190	609	640	420	605	430	540	90	210	70	840x870x750	86
W8 50 DX DB	0,75	230V/50Hz	21	410x2	545x460 h.190	609	640	420	605	424	428	90	210	75	840x870x750	87
W8 50 BX DB	0,75	230V/50Hz	21	410x2	545x460 h.190	609	640	420	605	424	428	90	210	75	840x870x750	87
W8 70 DX 40 TB	1,1	400V/50Hz	40	640x1 / 410x2	780x490 h.190	860	860	520	670	424	660	90	210	115	-	-
W8 70 BX 40 TB	1,1	400V/50Hz	40	640x1 / 410x2	780x490 h.190	860	860	520	670	424	660	90	210	115	-	-

Potencia  
Potencia  
Мощность

Alimentación  
Alimentação  
Питание

Bomba de vacío  
Bomba de vácuo  
Вакуумный насос

Barra de soldadura  
Schweißstee  
密封条

Dimensiones de la cavidad  
Dimensões das cavidades  
Размеры полости

A

B

C

D

E

F

G

H

Peso neto  
Peso líquido  
Вес нетто

Dimensiones embalaje  
Dimensões embalagem  
Размеры упаковки

Peso bruto  
Peso bruto  
Вес брутто