

style

design

Erfahrung

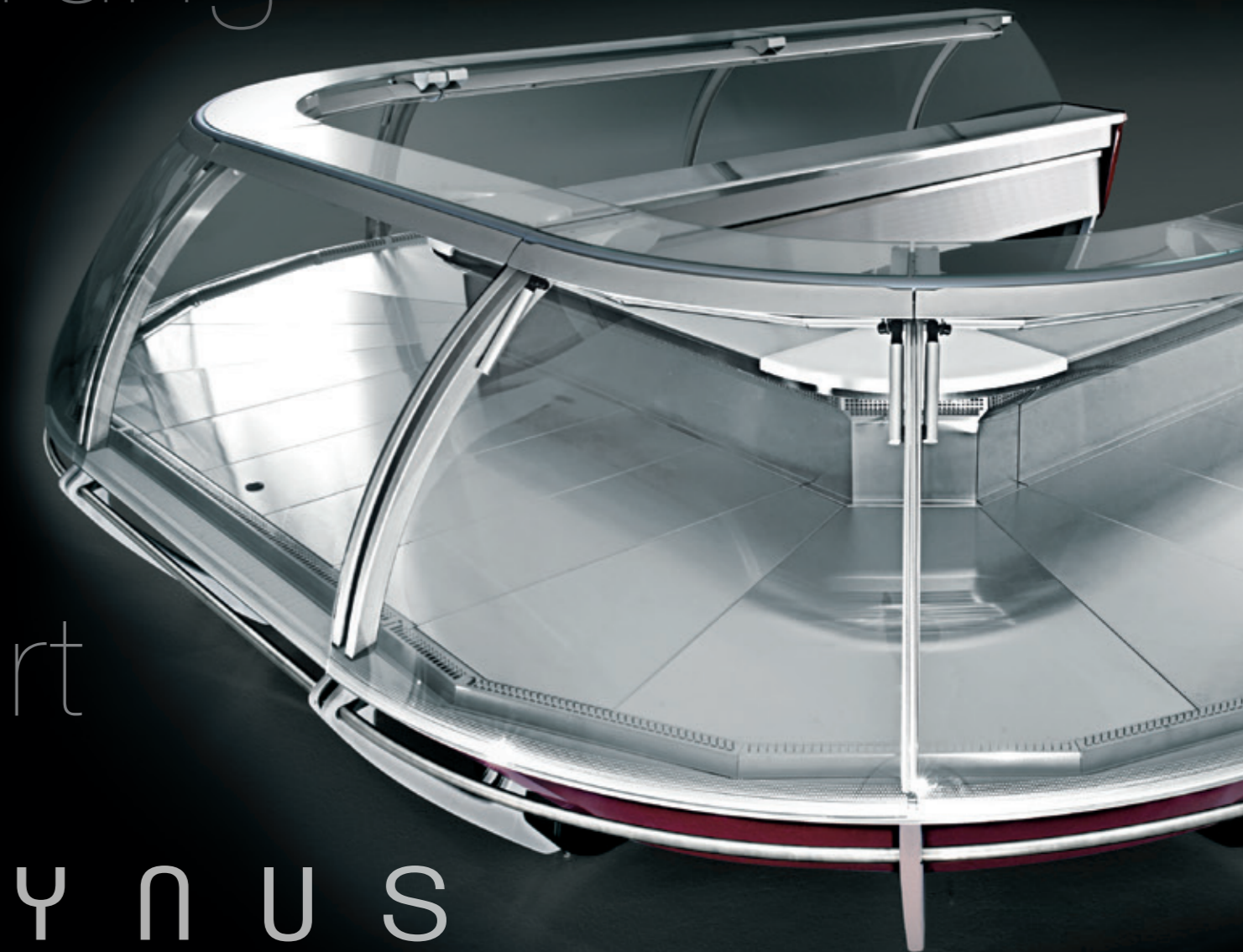

Wert

уникальность

S Y N U S

S Y N U S

A catching design.



Winding shapes and harmonious symmetry in a typical Italian "architecture".

Ein ergreifendes Design.

Geschwungene Formen und harmonische Symmetrie in einer typisch italienischen „Architektur“.

Гармоничный дизайн.

формы и гармоничная симметричность как типичный признак итальянской «архитектуры».



РУССКИЙ ПРОЕКТ
WWW.RP.RU

S Y N U S

A catching shape.



The lightness of a "poising" counter making the goods displayed the real protagonists on the stage.

Eine ergreifende Form.

Die Schwerelosigkeit einer „schwebenden“ Theke macht die Produkte zu echten Protagonisten.

Гармоничная форма.

Сбалансированная легкость исполнения витрины обеспечивает максимальное внимание к товару.

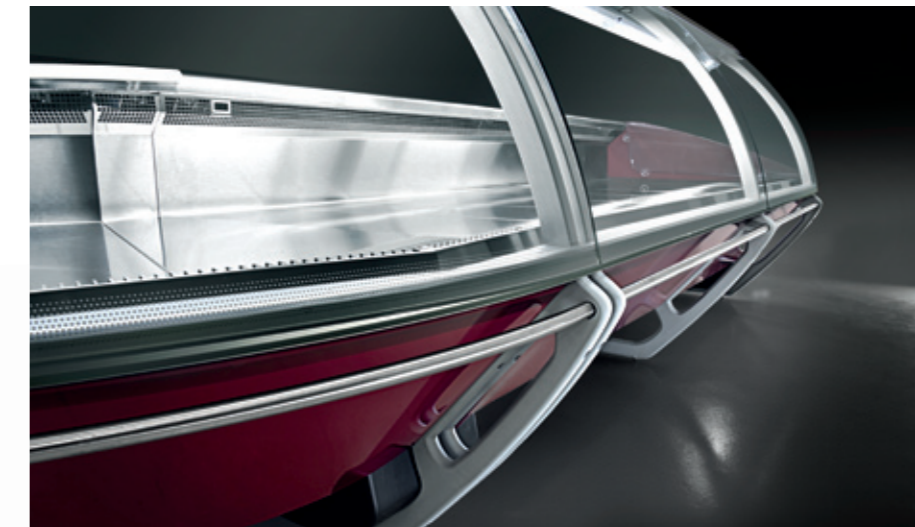

MEAT, DELI.
FLEISCH, GASTRONOMIE.
МЯСО, ГАСТРОНОМИЯ.

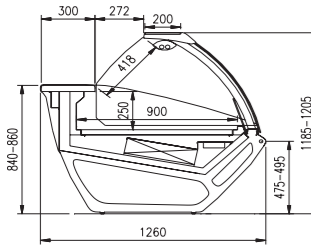

MEAT, DELI SELF-SERVICE.
FLEISCH, GASTRONOMIE SELBSTBEDIENUNG.
МЯСО, ГАСТРОНОМИЯ САМООБСЛУЖИВАНИЕ.

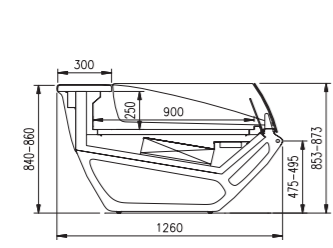

HOT SECTION.
HEISSE THEKE.
ГОРЯЧИЙ РАЗДЕЛ.

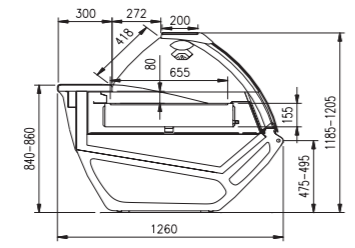

135° EXTERNAL CORNER.
AUSSENECKE 135°.
135 ГРАД ВНЕШ УГОЛ.

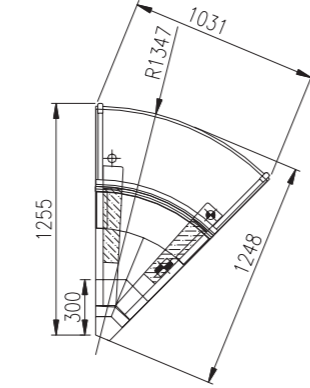

90° EXTERNAL CORNER.
AUSSENECKE 90°.
90 ГР ВНЕШ УГОЛ.

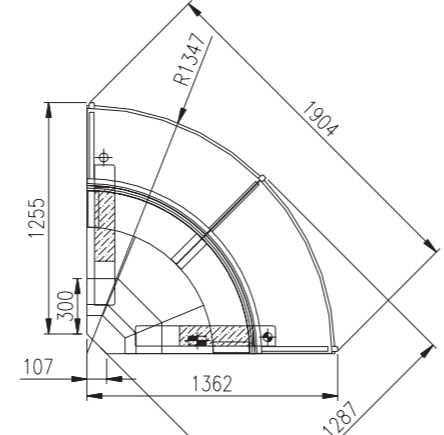

FISH.
FISCH.
РЫБА.

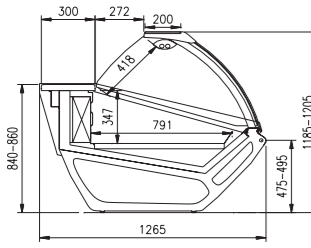

PASTRY.
GEBÄCK.
КОНДИТЕРКА.

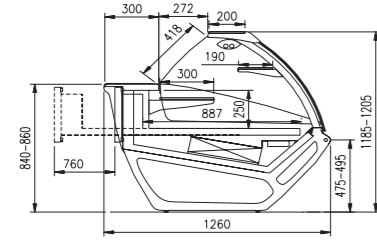

135° INTERNAL CORNER.
INNENECKE 135°.
135 ГР ВНУТР УГОЛ.

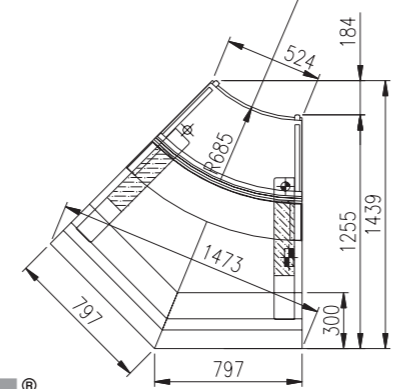

90° INTERNAL CORNER.
INNENECKE 90°.
90 ГР ВНУТР УГОЛ.

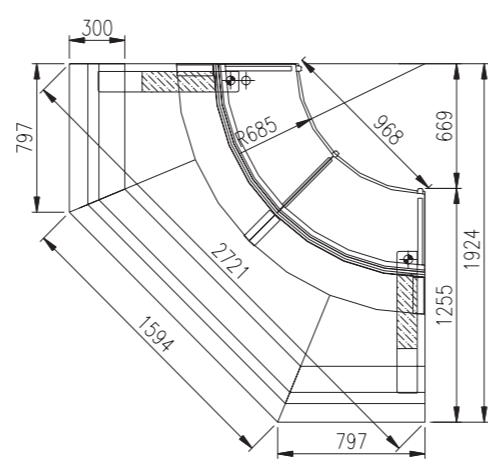

BREAD.
BROT.
ВЫПЕЧКА.

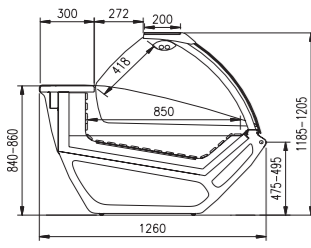

pastorfrigor
Italian Cold Style

РУССКИЙ ПРОЕКТ
WWW.RP.RU



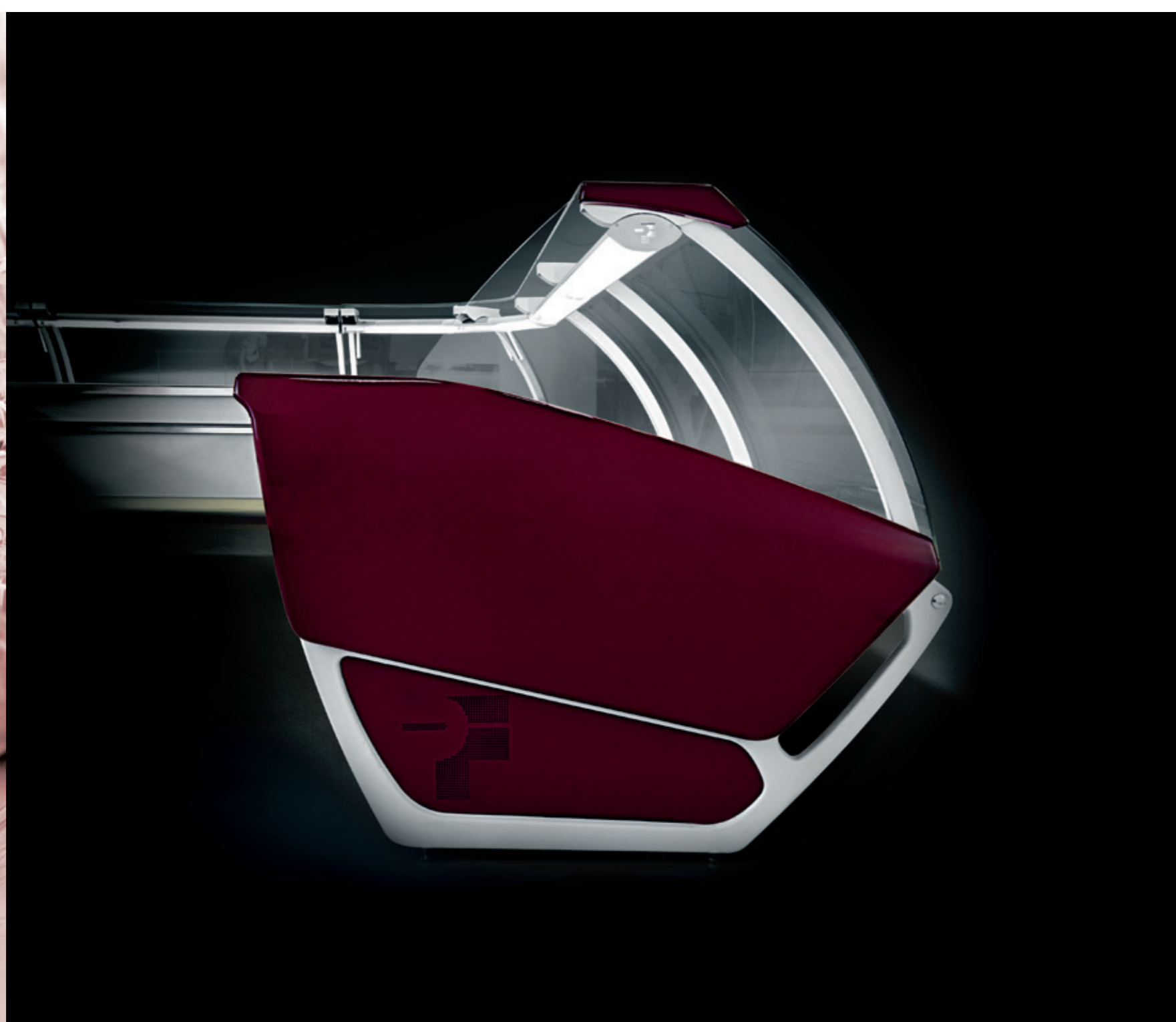
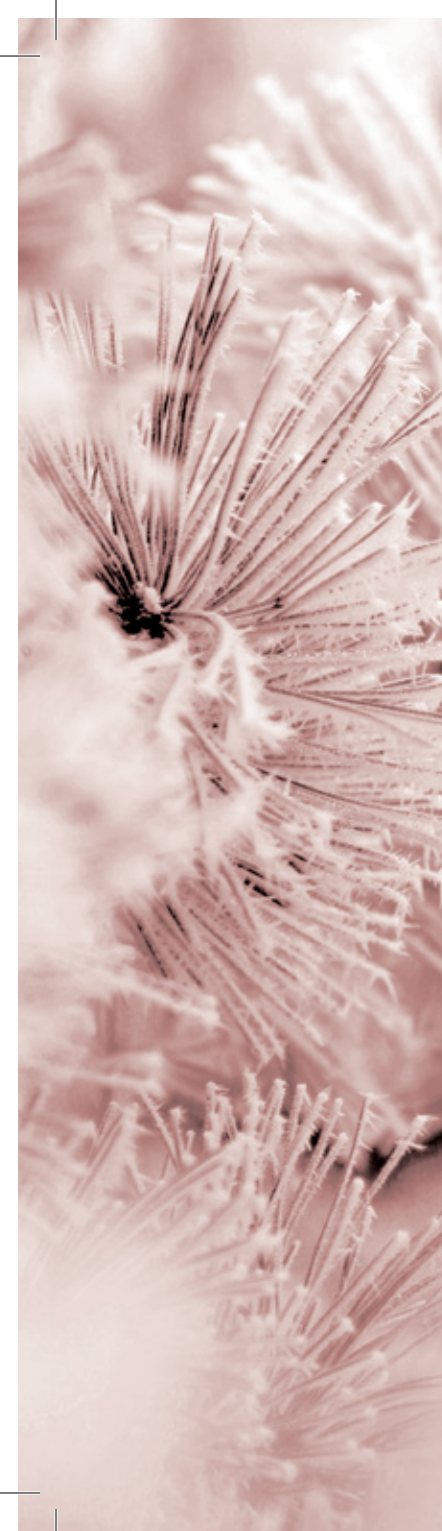

S Y N U S

Catching details.



Technology is at work in seeking a high degree of perfection for each single detail.

Ergreifende Details.

Die Technologie ist auf der Suche nach der Perfektion jedes einzelnen Details.

Гармония в деталях.

Совершенство каждой отдельной детали гарантирует идеальный результат.



125424, г. Москва, Волоколамское шоссе д. 88, стр. 8
тел./факс: +74955404600

РУССКИЙ ПРОЕКТ
WWW.RP.RU

